

Technical specifications

N° of cylinders	3
Total Capacity (kg)	3500
Motor (HP/KW)	5,5/4 (Max. 7,5/5,5)
Estimated Speed (cm/s)	6/8

MODEL WITHOUT DRIVER ON BOARD

DIMENSIONAL LIMITS

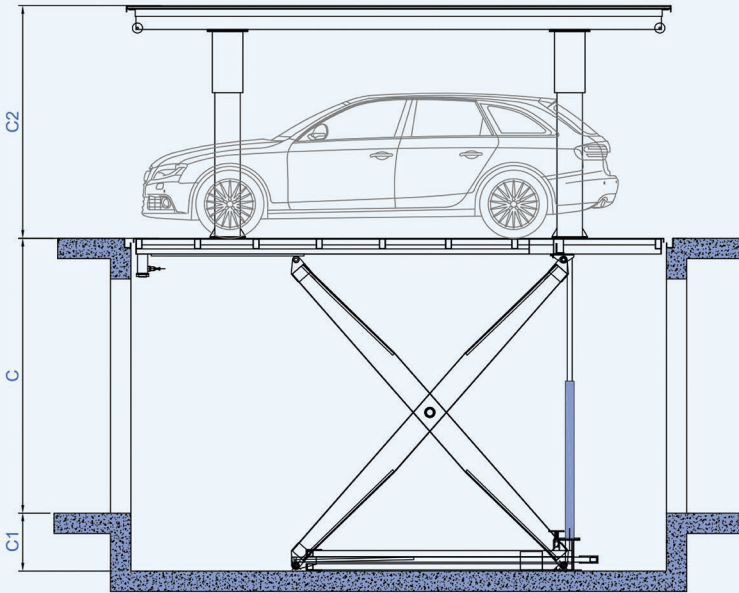

Section View-UP

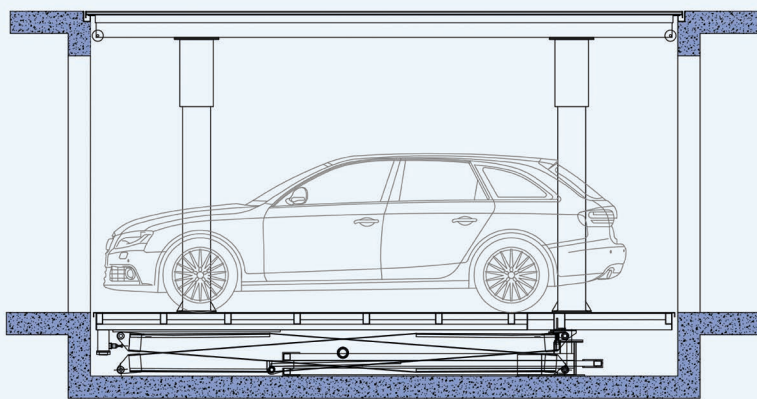

Section View-DOWN

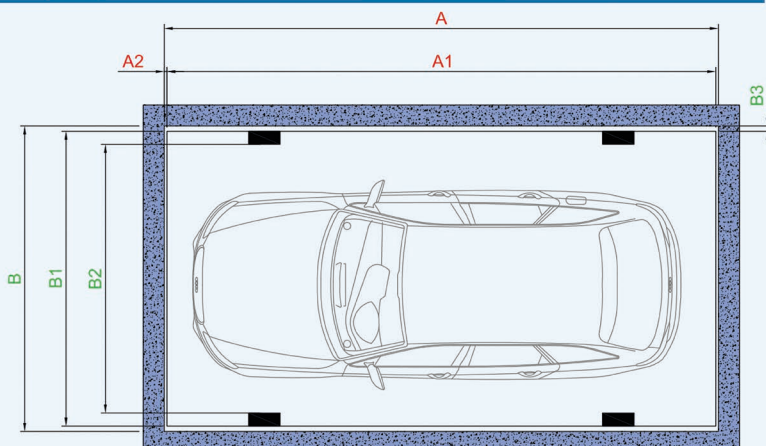

Plan View

Definition	Ref.	Min (mm)	Max (mm)
Pit lenght	A	4750*	6100*
Platform lenght	A1	4700	6050
Wall distance	A2	25	
Pit width	B	2500	3100
Platform width	B1	2450	3050
Clear passage	B2	2150	2750
Wall distance	B3	25	
Stroke (max reach.)	C	2700*	3800*
Extra pit	C1	570 / 620*	
Clear passage	C2	1800	2200

* for special requests please contact our technical department

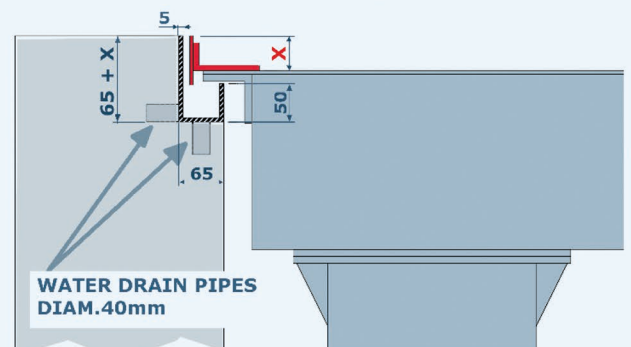

X = pavement height (mm)